

Important Information

Getting a new passport sized photograph to DVLA standard for your Freedom Pass

When applying for, or renewing, a Freedom Pass you must ensure that the standard of photograph you provide is of high quality and clarity – equal to that required by the DVLA.

To meet DVLA standard your photograph must be:

- A full face colour picture on a plain grey, cream or white background and taken within the last three years. It should include the whole head and not have any of the chin, top of head or ears missing.
- You must be facing forwards and looking straight at the camera with your eyes open and not laughing, smiling or frowning.
- Nothing must cover or obscure your eyes or face. Either remove glasses or make sure that the frame does not cover your eyes.
- The picture must be clear and in focus with no 'red eye', reflection or glare. Tinted glasses or sunglasses should not be worn. Dark glasses are permitted if worn for medical reasons.
- Do not wear a hat or cover your head except for medical or religious reasons.
- The photograph should be 45mm high x 35mm wide (1³/₄ x 1¹/₄ inches) and there should be space all around your head. It should be undamaged by creases, staples, paperclips or other marks.

Below is an example of a DVLA standard photograph.

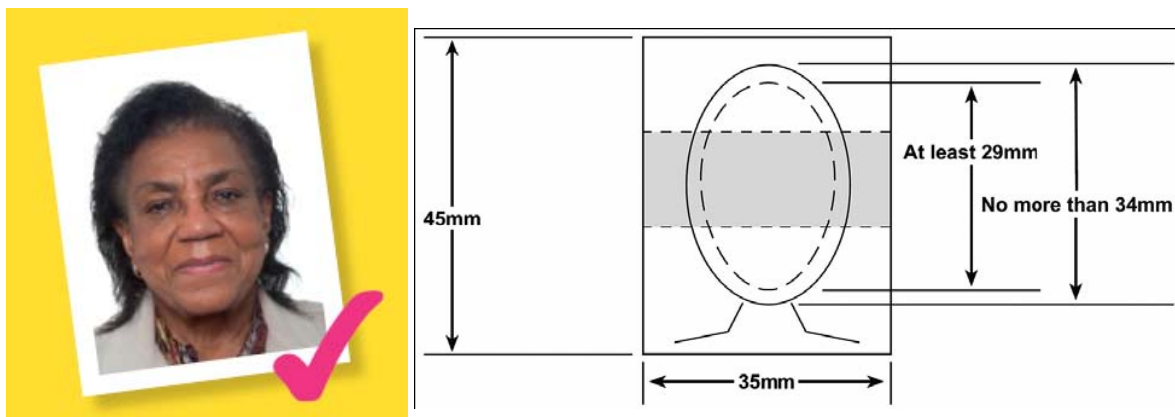

Some common reasons for photographs not being accepted



Not acceptable.
Top of head has been chopped off.



Not Acceptable.
Subject is smiling and the background is not plain grey, cream or white.



Not acceptable.
Hair covers the eyes and subject is laughing.

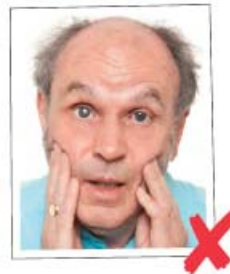

Not acceptable.
Part of the face is obscured.

If you wear glasses, either remove them or make sure the frames do not obscure your eyes and that the lenses give no reflection or glare.

Why do photographs need to be to DVLA standard?

The Freedom Passes issued from 2nd January 2010 onwards are considerably different than Freedom Passes issued before this date and due to the processes involved in production of these new style passes, it is important that the standard of photograph you provide is of high quality and clarity.

This is because the photograph you provide will be digitally scanned and printed directly onto the pass, similar to that of a modern day driver's licence, meaning that you will no longer require a separate photocard.

IF THE PHOTOGRAPH YOU PROVIDE IS NOT TO THE REQUIRED STANDARD, THE ISSUE OF YOUR PASS IS LIKELY TO BE DELAYED.

If you have any queries or need further advice about the standard of photograph required, please contact the Freedom Pass Advice Line on: **020 7934 9633** or **0845 275 7054** or send an email to mobility@londoncouncils.gov.uk

If you are physically unable to meet the required standards due to your disability please contact the Accessible Transport Unit directly on 020 8831 6191 / 6312.